



Specifications

SMART electric height-adjustable mobile stand

Model FSE-410

Overview

Designed for the current line of SMART Board® interactive displays in North America, the SMART electric height-adjustable mobile stand features 26" (66 cm) of powered height adjustment. Safety features include a safety stop mechanism that reverses direction briefly if an obstruction is encountered and a controller that locks height adjustment automatically to ensure that only people with proper training or supervision can use the stand. With its wide footprint and sturdy steel frame, the stand supports displays up to 86" (218 cm) diagonal that weigh up to 200 lb. (91 kg). The stand supports a maximum weight of 240 lb. (111 kg) with a display and accessories. You can easily roll the stand across smooth floors and secure it in place with the industrial grade 4" locking casters. The stand has a UL-certified drive system, is certified to UL 962 for Usage Area II, and complies with Americans with Disabilities Act (ADA) standards. It also includes VESA mounting points for easy installation of the display and peripherals, a locking storage cabinet, and a surge-protected power bar.

See smarttech.com for more information about this product.

Dimensions and weights¹

Dimensions

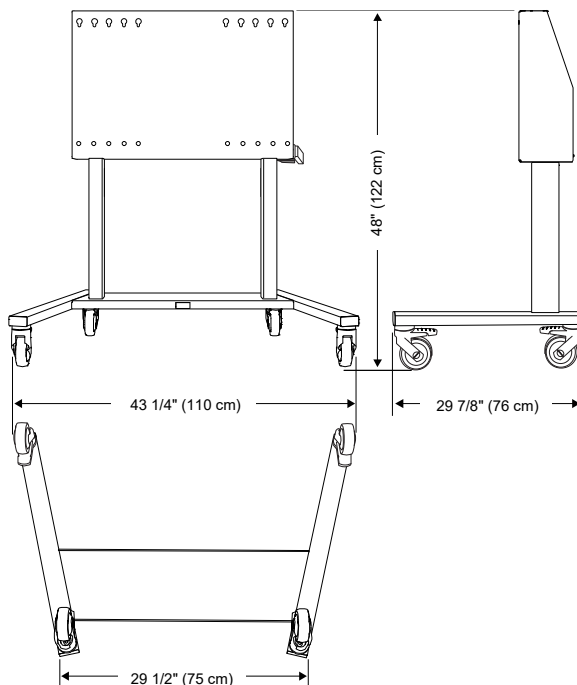

Weight

106 lb. (48 kg)

Shipping dimensions

45 2/8" × 32 5/8" × 7 3/8"
(115 cm × 83 cm × 19 cm)

Shipping weight

115 lb. (52.5 kg)

Storage cabinet dimensions

29 1/2" × 19 5/8" × 7 1/8"
(75 cm × 50 cm × 18.1 cm)

¹All dimensions ± 1/8" (0.3 cm). All weights ± 2 lb. (0.9 kg).

SMART electric height-adjustable mobile stand – Model FSE-410

Specifications

Hardware

Supported SMART Board displays	SMART Board GX series SMART Board MX, MX (V2), and MX Pro series SMART Board 6000 and 6000 Pro series SMART Board 6000S and 6000S Pro series SMART Board 7000, 7000 Pro series SMART Board 7000R and 7000R Pro series SMART Board 2000 series
--------------------------------	---

Maximum display size	Supports displays up to 86" (218 cm) diagonal and 80" (203 cm) wide
----------------------	---

Maximum display weight	200 lb. (91 kg)
------------------------	-----------------

Maximum total weight (display and accessories)	240 lb. (111 kg)
--	------------------

Height adjustment

Range	26" (66 cm)
-------	-------------

Maximum extended height	74" (188 cm)
-------------------------	--------------

Minimum extended height	48" (122 cm)
-------------------------	--------------

Components

Wheels	4" industrial-grade locking casters
--------	-------------------------------------

Mounting	VESA® mounting pattern: 300 mm × 400 mm – M8, 500 mm × 400 mm – M8, 600 mm × 400 mm – M8, 700 mm × 400 mm – M8, 400 mm × 200 mm – M8, 800 mm × 200 mm – M8 with adapter (not included)
----------	--

Storage and operating requirements

Power consumption

Supply voltage	100V–240V AC, 50 –60 Hz
----------------	-------------------------

Nominal voltage	110V AC, 220V AC
-----------------	------------------

ⓘ Important

The supplied power bar can only be used with 120V input.

Power consumption

Raising a display (maximum load)	300 W
----------------------------------	-------

Standby mode	0.1 W
--------------	-------

SMART electric height-adjustable mobile stand – Model FSE-410

Specifications

Duty cycle	10% (2 minutes of operation fully loaded, 18 minutes of rest)
Operating temperature	50–104°F (10–40°C)
Storage temperature	14–158°F (-10–70°C)
Humidity	85% non-condensing

Certification and compliance

Regulatory certification	FCC, ISED, UL Listed - U.S. and Canada UL 962 – Usage Area II
Other	ADA
Environmental compliance	
European Union	RoHS, REACH and Packaging Directive
U.S.	CONEG Packaging, California proposition 65

Purchasing information

Order numbers

FSE-410	SMART electric height-adjustable mobile stand
FSE-400-HL	Handles 8" x 6" x 4" (20.3 cm x 15.2 cm x 10.2 cm) 1 lb. 8 oz. (0.7 kg)
FSE-400-CH	Cable hook 8" x 6" x 4" (20.3 cm x 15.2 cm x 10.2 cm) 1 lb. (0.5 kg)
FSE-400-LS	Laptop shelf
Optional accessories	See smarttech.com/accessories
Warranty	Five-year limited equipment warranty

[smarttech.com/support](https://www.smarttech.com/support)
[smarttech.com/contactsupport](https://www.smarttech.com/contactsupport)

© 2020–2022 SMART Technologies ULC. All rights reserved. SMART Board, smarttech, the SMART logo and all SMART taglines are trademarks or registered trademarks of SMART Technologies ULC in the U.S. and/or other countries. All third-party product and company names may be trademarks of their respective owners. This product and/or use thereof is covered by one or more of the following U.S. patents: www.smarttech.com/patents. Contents are subject to change without notice. February 7, 2022.